

# Hexagon socket head cap screws (modified version of ISO 4762)

**DIN**  
**912**

Zylinderschrauben mit Innensechskant; ISO 4762 modifiziert

Supersedes September 1979 edition

*As it is current practice in standards published by the International Organization for Standardization (ISO), the comma has been used throughout as a decimal marker.*

This standard contains the main specifications of ISO 4762 – 1977, adopted in a modified form, with national addenda. These addenda are shaded grey in clauses 1 and 3 to 6.

Dimensions in mm

## 1 Field of application

This standard specifies product grade A hexagon socket head cap screws with metric screw threads and thread diameters from 1,4 to 100 mm <sup>1)</sup>. If, in exceptional cases, the screws are to meet requirements other than those given in this standard, these shall be selected in accordance with the appropriate standards.

## 2 Dimensions

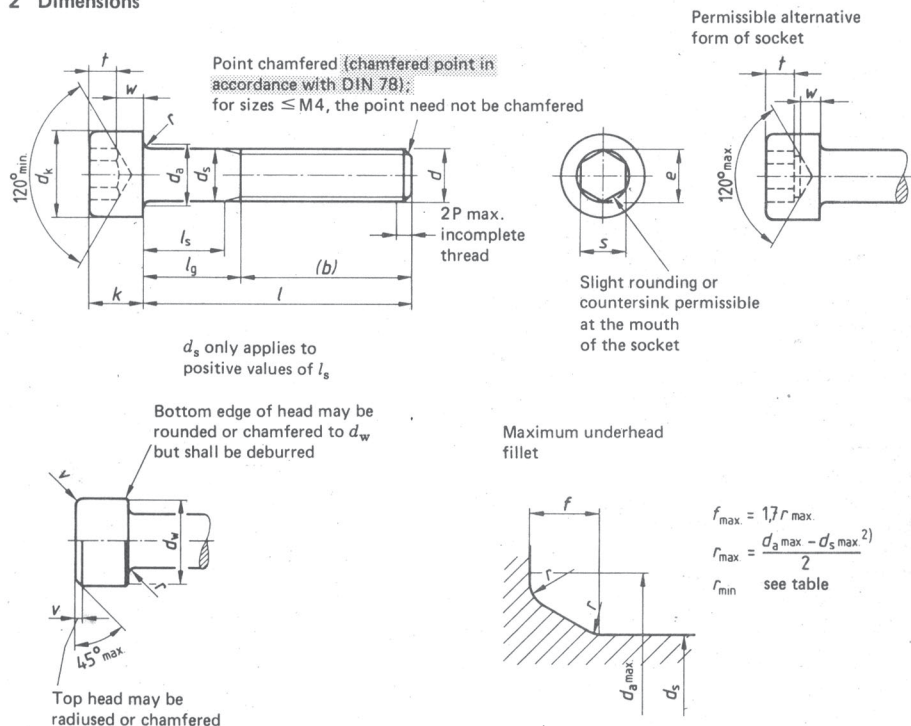

1) In ISO 4762, the range is M 1,6 to M 36.

2) In ISO 4762, this is given incorrectly as  $r_{max} = \frac{d_g - d_s}{2}$ ; an application has been made to ISO to correct this.

Continued on pages 2 to 12

Table 1.

Thread size $d$		M 1,4	M 1,6	M 2	M 2,5
		—	—	—	—
$P$ 1)		0,3	0,35	0,4	0,45
$b$	Reference dimension	14	15	16	17
$d_k$	max. 2)	2,6	3	3,8	4,5
	max. 3)	2,74	3,14	3,98	4,68
	min.	2,46	2,86	3,62	4,32
$d_a$	max.	1,8	2	2,6	3,1
$d_s$	max.	1,4	1,6	2	2,5
	min.	1,26	1,46	1,86	2,36
$e$	min. 4)	1,5	1,73	1,73	2,3
$f$	max.	0,34	0,34	0,51	0,51
$k$	max.	1,4	1,6	2	2,5
	min.	1,26	1,46	1,86	2,36
$r$	min.	0,1	0,1	0,1	0,1
$s$	Nominal dimension	1,3	1,5	1,5	2
	min.	1,32	1,52	1,52	2,02
	max.	1,36	1,56	1,56	2,06
$t$	min.	0,6	0,7	1	1,1
$v$	max.	0,14	0,16	0,2	0,25
$d_w$	min.	2,32	2,72	3,48	4,18
$w$	min.	0,5	0,55	0,55	0,85

$l$			Shank lengths $l_s$ and $l_g$							
			$l_s$		$l_g$		$l_s$		$l_g$	
Nominal length	min.	max.	min.	max.	min.	max.	min.	max.	min.	max.
2	1,8	2,2	—	0,9	—	—	—	—	—	—
2,5	2,3	2,7	—	0,9	—	1,05	—	—	—	—
3	2,8	3,2	—	0,9	—	1,05	—	1,2	—	—
4	3,76	4,24	—	0,9	—	1,05	—	1,2	—	1,35
5	4,76	5,24	—	0,9	—	1,05	—	1,2	—	1,35
6	5,76	6,24	—	0,9	—	1,05	—	1,2	—	1,35
8	7,71	8,29	—	0,9	—	1,05	—	1,2	—	1,35
10	9,71	10,29	—	0,9	—	1,05	—	1,2	—	1,35
12	11,65	12,35	—	0,9	—	1,05	—	1,2	—	1,35
16	15,65	16,35	—	—	—	1,05	—	1,2	—	1,35
20	19,58	20,42	—	—	—	—	—	1,2	—	1,35
25	24,58	25,42	—	—	—	—	—	—	—	1,35
30	29,58	30,42	—	—	—	—	—	—	—	—
35	34,5	35,5	—	—	—	—	—	—	—	—
40	39,5	40,5	—	—	—	—	—	—	—	—
45	44,5	45,5	—	—	—	—	—	—	—	—
50	49,5	50,5	—	—	—	—	—	—	—	—
55	54,4	55,6	—	—	—	—	—	—	—	—
60	59,4	60,6	—	—	—	—	—	—	—	—
65	64,4	65,6	—	—	—	—	—	—	—	—
70	69,4	70,6	—	—	—	—	—	—	—	—
80	79,4	80,6	—	—	—	—	—	—	—	—

1)  $P$  = Thread pitch of coarse thread in accordance with DIN 13 Part 12.

2) For plain heads.

3) For knurled heads and for heads with designation on circumference.

4)  $e$  min. =  $1,14 \cdot s$  min.

Table 1. (Continued)

Thread size $d$		M 3	M 4	M 5	M 6	M 8							
		—	—	—	—	M 8 × 1							
$P$ 1)		0,5	0,7	0,8	1	1,25							
$b$	Reference dimension	18	20	22	24	28							
$d_k$	max. 2)	5,5	7	8,5	10	13							
	max. 3)	5,68	7,22	8,72	10,22	13,27							
	min.	5,32	6,78	8,28	9,78	12,73							
$d_a$	max.	3,6	4,7	5,7	6,8	9,2							
$d_s$	max.	3	4	5	6	8							
	min.	2,86	3,82	4,82	5,82	7,78							
$e$	min. 4)	2,87	3,44	4,58	5,72	6,86							
$f$	max.	0,51	0,6	0,6	0,68	1,02							
$k$	max.	3	4	5	6	8							
	min.	2,86	3,82	4,82	5,7	7,64							
$r$	min.	0,1	0,2	0,2	0,25	0,4							
$s$	Nominal dimension	2,5	3	4	5	6							
	min.	2,52	3,02	4,02	5,02	6,02							
	max.	2,58	3,08	4,095	5,14	6,14							
$t$	min.	1,3	2	2,5	3	4							
$v$	max.	0,3	0,4	0,5	0,6	0,8							
$d_w$	min.	5,07	6,53	8,03	9,38	12,33							
$w$	min.	1,15	1,4	1,9	2,3	3							
$l$		Shank lengths $l_s$ and $l_g$											
		$l_s$	$l_g$	$l_s$	$l_g$	$l_s$	$l_g$	$l_s$	$l_g$	$l_s$	$l_g$	$l_s$	$l_g$
Nominal length	min.	max.	min.	max.	min.	max.	min.	max.	min.	max.	min.	max.	
2	1,8	2,2											
2,5	2,3	2,7											
3	2,8	3,2											
4	3,76	4,24											
5	4,76	5,24	—	1,5									
6	5,76	6,24	—	1,5	—	2,1							
8	7,71	8,29	—	1,5	—	2,1	—	2,4					
10	9,71	10,29	—	1,5	—	2,1	—	2,4	—	3			
12	11,65	12,35	—	1,5	—	2,1	—	2,4	—	3	—	3,75	
16	15,65	16,35	—	1,5	—	2,1	—	2,4	—	3	—	3,75	
20	19,58	20,42	—	1,5	—	2,1	—	2,4	—	3	—	3,75	
25	24,58	25,42	4,5	7	—	2,1	—	2,4	—	3	—	3,75	
30	29,58	30,42	9,5	12	6,5	10	4	8	—	3	—	3,75	
35	34,5	35,5			11,5	15	9	13	6	11	—	3,75	
40	39,5	40,5			16,5	20	14	18	11	16	5,75	12	
45	44,5	45,5					19	23	16	21	10,75	17	
50	49,5	50,5					24	28	21	26	15,75	22	
55	54,4	55,6							26	31	20,75	27	
60	59,4	60,6							31	36	25,75	32	
65	64,4	65,6									30,75	37	
70	69,4	70,6									35,75	42	
80	79,4	80,6									45,75	52	

For 1) to 4) see page 2.

Table 1. (Continued)

Thread size $d$		M 10		M 12		(M 14)		M 16		(M 18)			
		M 10 × 1,25		M 12 × 1,25		(M 14 × 1,5)		M 16 × 1,5		(M 18 × 1,5)			
		M 10 × 1		M 12 × 1,5		—		—		(M 18 × 2)			
$P$ 1)		1,5		1,75		2		2		2,5			
$b$	Reference dimension	32		36		40		44		48			
$d_k$	max. 2)	16		18		21		24		27			
	max. 3)	16,27		18,27		21,33		24,33		27,33			
	min.	15,73		17,73		20,67		23,67		26,67			
$d_a$	max.	11,2		13,7		15,7		17,7		20,2			
$d_s$	max.	10		12		14		16		18			
	min.	9,78		11,73		13,73		15,73		17,73			
$e$	min. 4)	9,15		11,43		13,72		16		16			
$f$	max.	1,02		1,87		1,87		1,87		1,87			
$k$	max.	10		12		14		16		18			
	min.	9,64		11,57		13,57		15,57		17,57			
$r$	min.	0,4		0,6		0,6		0,6		0,6			
$s$	Nominal dimension	8		10		12		14		14			
	min.	8,025		10,025		12,032		14,032		14,032			
	max.	8,175		10,175		12,212		14,212		14,212			
$t$	min.	5		6		7		8		9			
$v$	max.	1		1,2		1,4		1,6		1,8			
$d_w$	min.	15,33		17,23		20,17		23,17		25,87			
$w$	min.	4		4,8		5,8		6,8		7,8			
$l$		Shank lengths $l_s$ and $l_g$											
		Nominal length		$l_s$		$l_g$		$l_s$		$l_g$		$l_s$	
min.	max.			min.	max.	min.	max.	min.	max.	min.	max.	min.	max.
16	15,65	16,35	—	4,5	—	—	—	—	—	—	—	—	—
20	19,58	20,42	—	4,5	—	5,25	—	—	—	—	—	—	—
25	24,58	25,42	—	4,5	—	5,25	—	6	—	6	—	—	—
30	29,58	30,42	—	4,5	—	5,25	—	6	—	6	—	—	7,5
35	34,5	35,5	—	4,5	—	5,25	—	6	—	6	—	—	7,5
40	39,5	40,5	—	4,5	—	5,25	—	6	—	6	—	—	7,5
45	44,5	45,5	5,5	13	—	5,25	—	6	—	6	—	—	7,5
50	49,5	50,5	10,5	18	—	5,25	—	6	—	6	—	—	7,5
55	54,4	55,6	15,5	23	10,25	19	—	6	—	6	—	—	7,5
60	59,4	60,6	20,5	28	15,25	24	10	20	—	6	—	—	7,5
65	64,4	65,6	25,5	33	20,25	29	15	25	11	21	—	—	7,5
70	69,4	70,6	30,5	38	25,25	34	20	30	16	26	9,5	22	—
80	79,4	80,6	40,5	48	35,25	44	30	40	26	36	19,5	32	—
90	89,3	90,7	50,5	58	45,25	54	40	50	36	46	29,5	42	—
100	99,3	100,7	60,5	68	55,25	64	50	60	46	56	39,5	52	—
110	109,3	110,7	—	—	65,25	74	60	70	56	66	49,5	62	—
120	119,3	120,7	—	—	75,25	84	70	80	66	76	59,5	72	—
130	129,2	130,8	—	—	—	—	80	90	76	86	69,5	82	—
140	139,2	140,8	—	—	—	—	90	100	86	96	79,5	92	—
150	149,2	150,8	—	—	—	—	—	—	96	106	89,5	102	—
160	159,2	160,8	—	—	—	—	—	—	106	116	99,5	112	—
180	179,2	180,8	—	—	—	—	—	—	—	—	119,5	132	—
200	199,1	200,9	—	—	—	—	—	—	—	—	—	—	—

For 1) to 4) see page 2.

Table 1. (Continued)

Thread size $d$		M 20	(M 22)	M 24	(M 27)	M 30							
		M 20 × 1,5	(M 22 × 1,5)	M 24 × 2	(M 27 × 2)	M 30 × 2							
		M 20 × 2	(M 22 × 2)	—	—	—							
$P$ 1)		2,5	2,5	3	3	3,5							
$b$	Reference dimension	52	56	60	66	72							
$d_k$	max. 2)	30	33	36	40	45							
	max. 3)	30,33	33,39	36,39	40,39	45,39							
	min.	29,67	32,61	35,61	39,61	44,61							
$d_a$	max.	22,4	24,4	26,4	30,4	33,4							
	max.	20	22	24	27	30							
$d_s$	min.	19,67	21,67	23,67	26,67	29,67							
	min. 4)	19,44	19,44	21,73	21,73	25,15							
$f$	max.	2,04	2,04	2,04	2,89	2,89							
$k$	max.	20	22	24	27	20							
	min.	19,48	21,48	23,48	26,48	29,48							
$r$	min.	0,8	0,8	0,8	1	1							
$s$	Nominal dimension	17	17	19	19	22							
	min.	17,05	17,05	19,065	19,065	22,065							
	max.	17,23	17,23	19,275	19,275	22,275							
$t$	min.	10	11	12	13,5	15,5							
$v$	max.	2	2,2	2,4	2,7	3							
$d_w$	min.	28,87	31,81	34,81	38,61	43,61							
$w$	min.	8,6	9,4	10,4	11,9	13,1							
$l$		Shank lengths $l_s$ and $l_g$											
		Nominal length		$l_s$	$l_g$	$l_s$	$l_g$	$l_s$	$l_g$	$l_s$	$l_g$	$l_s$	$l_g$
	min.	max.	min.	max.	min.	max.	min.	max.	min.	max.	min.	max.	
16	15,65	16,35											
20	19,58	20,42											
25	24,58	25,42											
30	29,58	30,42	—	7,5									
35	34,5	35,5	—	7,5	—	7,5							
40	39,5	40,5	—	7,5	—	7,5	—	9					
45	44,5	45,5	—	7,5	—	7,5	—	9	—	9	—	10,5	
50	49,5	50,5	—	7,5	—	7,5	—	9	—	9	—	10,5	
55	54,4	55,6	—	7,5	—	7,5	—	9	—	9	—	10,5	
60	59,4	60,6	—	7,5	—	7,5	—	9	—	9	—	10,5	
65	64,4	65,6	—	7,5	—	7,5	—	9	—	9	—	10,5	
70	69,4	70,6	—	7,5	—	7,5	—	9	—	9	—	10,5	
80	79,4	80,6	15,5	28	11,5	24	—	9	—	9	—	10,5	
90	89,3	90,7	25,5	38	21,5	34	15	30	—	9	—	10,5	
100	99,3	100,7	35,5	48	31,5	44	25	40	19	34	—	10,5	
110	109,3	110,7	45,5	58	41,5	54	35	50	29	44	20,5	38	
120	119,3	120,7	55,5	68	51,5	64	45	60	39	54	30,5	48	
130	129,2	130,8	65,5	78	61,5	74	55	70	49	64	40,5	58	
140	139,2	140,8	75,5	88	71,5	84	65	80	59	74	50,5	68	
150	149,2	150,8	85,5	98	81,5	94	75	90	69	84	60,5	78	
160	159,2	160,8	95,5	108	91,5	104	85	100	79	94	70,5	88	
180	179,2	180,8	115,5	128	111,5	124	105	120	99	114	90,5	108	
200	199,1	200,9	135,5	148	131,5	144	125	140	119	134	110,5	128	

For 1) to 4) see page 2.

Table 1. (Continued)

Thread size $d$		(M 33)	M 36	M 42	M 48	M 56							
		(M 33 × 2)	M 36 × 3	M 42 × 3	M 48 × 3	M 56 × 4							
$P$ 1)		3,5	4	4,5	5	6,5							
$b$	Reference dimension	78	84	96	108	124							
$d_k$	max. 2)	50	54	63	72	84							
	max. 3)	50,39	54,46	63,46	72,46	84,54							
	min.	49,61	53,54	62,54	71,54	83,46							
$d_a$	max.	36,4	39,4	45,5	52,6	63							
$d_s$	max.	33	36	42	48	56							
	min.	32,61	35,61	41,61	47,61	55,54							
$e$	min. 4)	27,43	30,85	36,57	41,13	46,83							
$f$	max.	2,89	2,89	3,06	3,91	5,95							
$k$	max.	33	36	42	48	56							
	min.	32,38	35,38	41,38	47,38	56,26							
$r$	min.	1	1	1,2	1,6	2							
$s$	Nominal dimension	24	27	32	36	41							
	min.	24,065	27,065	32,08	36,08	41,08							
	max.	24,275	27,275	32,33	36,33	41,33							
$t$	min.	18	19	24	28	34							
$v$	max.	3,3	3,6	4,2	4,8	5,5							
$d_w$	min.	48,61	52,54	61,34	70,34	82,26							
$w$	min.	13,5	15,3	16,3	17,5	19							
$l$		Shank lengths $l_s$ and $l_g$											
		$l_s$	$l_g$	$l_s$	$l_g$	$l_s$	$l_g$	$l_s$	$l_g$	$l_s$	$l_g$	$l_s$	$l_g$
Nominal length	min.	max.	min.	max.	min.	max.	min.	max.	min.	max.	min.	max.	
50	49,5	50,5	—	10,5	—	—	—	—	—	—	—	—	
55	54,4	55,6	—	10,5	—	12	—	—	—	—	—	—	
60	59,4	60,6	—	10,5	—	12	—	13,5	—	—	—	—	
65	64,4	65,6	—	10,5	—	12	—	13,5	—	—	—	—	
70	69,4	70,6	—	10,5	—	12	—	13,5	—	15	—	—	
80	79,4	80,6	—	10,5	—	12	—	13,5	—	15	—	16,5	
90	89,3	90,7	—	10,5	—	12	—	13,5	—	15	—	16,5	
100	99,3	100,7	—	10,5	—	12	—	13,5	—	15	—	16,5	
110	109,3	110,7	14,5	32	—	12	—	13,5	—	15	—	16,5	
120	119,3	120,7	24,5	42	16	36	—	13,5	—	15	—	16,5	
130	129,2	130,8	34,5	52	26	46	—	13,5	—	15	—	16,5	
140	139,2	140,8	44,5	62	36	56	21,5	44	—	15	—	16,5	
150	149,2	150,8	54,5	72	46	66	31,5	54	—	15	—	16,5	
160	159,2	160,8	64,5	82	56	76	41,5	64	27	52	—	16,5	
180	179,2	180,8	84,5	102	76	96	61,5	84	47	72	56	56	
200	199,1	200,9	104,5	122	96	116	81,5	104	67	92	48,5	76	
220	219,1	220,9	124,5	142	116	136	101,5	124	87	112	68,5	96	
240	239,1	240,9	144,5	162	136	156	121,5	144	107	132	88,5	116	
260	258,95	261,05	164,5	182	156	176	141,5	164	127	152	108,5	136	
280	278,95	281,05	184,5	202	176	196	161,5	184	147	172	128,5	156	
300	298,95	301,05	204,5	222	196	216	181,5	204	167	192	148,5	176	

For 1) to 4) see page 2.

Table 1. (Continued)

Thread size $d$		M 64	M 72 × 6	M 80 × 6	M 90 × 6	M 100 × 6						
		M 64 × 4	M 72 × 4	M 80 × 4	M 90 × 4	M 100 × 4						
$P$ 1)		6	6	6	6	6						
$b$	Reference dimension	140	156	172	192	212						
$d_k$	max. 2)	96	108	120	135	150						
	max. 3)	96,54	108,54	120,54	135,63	150,63						
	min.	95,46	107,46	119,46	134,37	149,37						
$d_a$	max.	71	79	87	97	107						
$d_s$	max.	64	72	80	90	100						
	min.	63,54	71,54	79,54	89,46	99,46						
$e$	min. 4)	52,53	62,81	74,21	85,61	97,04						
$f$	max.	5,95	5,95	5,95	5,95	5,95						
$k$	max.	64	72	80	90	100						
	min.	63,26	71,26	79,26	89,13	99,13						
$r$	min.	2	2	2	2,5	2,5						
$s$	Nominal dimension	46	55	65	75	85						
	min.	46,08	55,10	65,10	75,10	85,12						
	max.	46,33	55,40	65,40	75,40	85,47						
$t$	min.	38	43	48	54	60						
$v$	max.	6,4	7,2	8	9	10						
$d_w$	min.	94,26	106,26	118,16	133,17	148,17						
$w$	min.	22	25	27	32	34						
$l$		Shank lengths $l_s$ and $l_g$										
		$l_s$	$l_g$	$l_s$	$l_g$	$l_s$	$l_g$	$l_s$	$l_g$	$l_s$	$l_g$	
Nominal length	min.	max.	min.	max.	min.	max.	min.	max.	min.	max.	min.	max.
50	49,5	50,5										
55	54,4	55,6										
60	59,4	60,6										
65	64,4	65,6										
70	69,4	70,6										
80	79,4	80,6										
90	89,3	90,7	—	18								
100	99,3	100,7	—	18	—	18						
110	109,3	110,7	—	18	—	18						
120	119,3	120,7	—	18	—	18	—	18				
130	129,2	130,8	—	18	—	18	—	18				
140	139,2	140,8	—	18	—	18	—	18	—	18		
150	149,2	150,8	—	18	—	18	—	18	—	18	—	18
160	159,2	160,8	—	18	—	18	—	18	—	18	—	18
180	179,2	180,8	—	18	—	18	—	18	—	18	—	18
200	199,1	200,9	30	60	—	18	—	18	—	18	—	18
220	219,1	220,9	50	80	34	64	—	18	—	18	—	18
240	239,1	240,9	70	100	54	84	38	68	—	18	—	18
260	258,95	261,05	90	120	74	104	58	88	38	68	—	18
280	278,95	281,05	110	140	94	124	78	108	58	88	38	68
300	298,95	301,05	130	160	114	144	98	128	78	108	58	88

For 1) to 4) see page 2.

The commercial nominal lengths are designated by giving the shank lengths  $l_s$  and/or  $l_g$ .

Thread sizes and intermediate lengths given in brackets shall be avoided where possible.

Nominal lengths above 300 mm shall be in 20 mm steps.

Screws with nominal length above the dashed stepped line are threaded to head (distance between the last full thread and the head bearing surface  $l_g$  max. = 3  $P$ ). Screws with nominal lengths below the dashed stepped line have  $l_g$  and  $l_s$  values in accordance with the following formulae:  $l_g$  max. =  $l$  (nominal length) -  $b$  (reference dimension);  $l_s$  min. =  $l_g$  max. - 5  $P$ .The values given for  $l_s$  and  $l_g$  apply to screws with coarse threads.

### 3 Technical delivery conditions

Material		Steel	Stainless steel	Non-ferrous metal
General requirements		In accordance with DIN 267 Part 1.		
Thread	Tolerance	5g6g for property class 12.9; 6g <sup>1)</sup> for other property classes.		
	Standard	ISO 261, ISO 965	DIN 13 Part 12 and Part 15	
Mechanical properties	Property class (material)	≤ M39 <sup>2)</sup> : 8.8; 10.9; 12.9 > M39: as agreed	≤ M20: A2-70; A4-70 > M20 ≤ M39: A2-50 <sup>3)</sup> A4-50 ≤ M 39: C3 > M 39: as agreed	.....
	Standard	DIN ISO 898 Part 1	ISO 3506 <sup>4)</sup> DIN 267 Part 11 <sup>4)</sup>	DIN 267 Part 18 <sup>5)</sup>
Tolerances on dimensions and form	Product grade	A		
	Standard	ISO 4759/1/DIN ISO 4759 Part 1		
Surface		Black oxide (thermal or chemical)	Bright	Bright
		DIN 267 Part 2 (at present at the stage of draft) shall apply with regard to the peak-to-valley heights of the surface. DIN 267 Part 19 shall apply with regard to the permissible surface defects. DIN 267 Part 9 shall apply with regard to electroplating. If different electroplating or other surface protection is desired, this shall be agreed upon at the time of ordering.		
Acceptance testing	DIN 267 Part 5 shall apply with regard to acceptance testing.			
<sup>1)</sup> Only for screws without surface protection. 6g makes it possible for normal coating thicknesses to be applied in accordance with DIN 267 Part 9 but the reference line shall not be exceeded. Depending on the coating thickness required, a larger fundamental deviation shall be selected than that for the g position. A larger fundamental deviation may impair the stripping strength of the screw/nut connection. <sup>2)</sup> In ISO 4762, only up to M 36 or below. <sup>3)</sup> In ISO 4742 A2-80 is not correct, and an application has been made to ISO for a correction. <sup>4)</sup> The content of ISO 3506 is covered by DIN 267 Part 11. It was still being prepared when ISO 4762 – 1977 was published. <sup>5)</sup> A selection of materials from DIN 267 Part 18 will be specified later for hexagon socket head cap screws.				

### 4 Designation

Designation of a hexagon socket head cap screw with M 12 screw thread, nominal length  $l = 60$  mm and assigned to property class 12.9: **Hexagon socket head cap screw DIN 912 – M 12 × 60 – 12.9**

DIN 962 shall apply with regard to the designation of types and designs with additional data to be given when ordering, e. g. type B with shank diameter  $\approx$  pitch diameter.

DIN 6900 shall apply with regard to the designation of designs with captive components (screw assemblies).

DIN 7500 applies with regard to the designation of designs with thread-forming properties.

The international designation for hexagon socket head cap screws in accordance with ISO 4762 (not the shaded data) is, e. g.:

**Hexagon socket head cap screw ISO 4762 – M 12 × 60 – 12.9**

At present, the ISO 4762 designation does not include an acceptance test in accordance with DIN 267 Part 5.

DIN 4000 – 2 – 1 tabular layout of article characteristics shall apply to screws in accordance with this standard.



## 5 Mass

The values of mass given are guidance values and are given for the commercial lengths.

Table 2.

Thread size <i>d</i>	M 1,4	M 1,6	M 2	M 2,5	M 3	M 4	M 5	M 6	M 8	M 10	M 12	(M 14)	M 16	(M 18)	M 20
Nominal length <i>l</i>	Mass (7,85 kg/dm <sup>3</sup> ) kg per 1000 units ≈														
2	0,055														
2,5	0,060	0,085													
3	0,065	0,090	0,155												
4	0,075	0,100	0,175	0,345											
5	0,085	0,110	0,195	0,375	0,67										
6	0,095	0,120	0,215	0,405	0,71	1,50									
9	0,115	0,140	0,255	0,465	0,80	1,65	2,45								
10	0,135	0,160	0,295	0,525	0,88	1,80	2,70	4,70							
12	0,155	0,180	0,355	0,585	0,96	1,95	2,95	5,07	10,9						
16		0,220	0,415	0,705	1,16	2,25	3,45	5,75	12,1	20,9					
20			0,495	0,825	1,36	2,65	4,01	6,53	13,4	22,9	32,1				
25				0,975	1,61	3,15	4,78	7,59	15,0	25,4	35,7	48,0	71,3		
30					1,86	3,65	5,55	8,30	16,9	27,9	39,3	53,0	77,8	111	128
35						4,15	6,32	9,91	18,9	30,4	42,9	58,0	84,4	120	139
40						4,65	7,09	11,0	20,9	32,9	46,5	63,0	91,0	129	150
45							7,86	12,1	22,9	36,1	50,1	68,0	97,6	138	161
50							8,63	13,2	24,9	39,3	54,5	73,0	106	147	172
55								14,3	26,9	42,5	58,9	78,0	114	156	183
60								15,4	28,9	45,7	63,4	84,0	122	165	194
65									31,0	48,9	67,8	90,0	130	174	205
70									33,0	52,1	71,3	96,0	138	183	216
80									37,0	58,5	80,2	108	154	203	241
90										64,9	89,1	120	170	223	266
100										71,2	98,0	132	186	243	291
110											107	144	202	263	316
120											116	156	218	283	341
130												168	234	303	366
140												180	250	323	391
150													266	343	416
160													282	363	441
180														403	491
200															541

For hexagon socket head cap screws with fine threads, approximately the same masses may be assumed.

Table 2. (Continued)

Thread size <i>d</i>	(M 22)	M 24	(M 27)	M 30	(M 33)	M 36	M 42	M 48	M 56	M 64	M 72 × 6	M 80 × 6	M 90 × 6	M 100 × 6
Nominal length <i>l</i>	Mass (7,85 kg/dm <sup>3</sup> ) kg per 1000 units ≈													
35	211													
40	224	270												
45	237	285	330	500										
50	250	300	352	527	630									
55	263	316	374	554	665	870								
60	276	330	396	581	700	910	1370							
65	291	345	418	608	735	950	1420							
70	306	363	440	635	770	990	1470	2040						
80	336	399	484	690	830	1070	1580	2180						
90	366	435	529	745	900	1150	1680	2320						
100	396	471	574	800	970	1230	1790	2460						
110	426	507	619	855	1040	1310	1890	2600						
120	456	543	664	910	1110	1390	2000	2740						
130	486	579	709	965	1180	1470	2100	2880						
140	516	615	754	1020	1250	1550	2210	3020						
150	546	651	799	1080	1320	1630	2320	3160						
160	576	687	844	1130	1390	1710	2420	3300	4880					
180	636	759	934	1240	1530	1870	2640	3590	5270	7 250				
200	696	831	1020	1350	1670	2030	2860	3870	5650	7 750	9 950			
220	756	903	1110	1460	1810	2190	3080	4150	6040	8 250	10 600			
240		975	1230	1570	1950	2250	3300	4430	6420	8 750	11 300	14 300		
260			1340	1680	2040	2410	3520	4710	6810	9 260	11 900	15 100	19 900	25 700
280				1790	2180	2570	3740	4990	7200	9 760	12 600	15 800	20 900	26 900
300				1900	2320	2730	3960	5270	7580	10 300	13 300	16 600	21 900	28 200

## Standards referred to

## a) in ISO 4762 – 1977

- ISO 261 – 1973 ISO general purpose metric screw threads – General plan (see DIN 13 Part 12)
- ISO 888 – 1976 Bolts, screws and studs – Nominal lengths and thread lengths for general purpose bolts (no comparable DIN Standard available; the ISO Standard has been taken into account in the relevant DIN Standards on bolts and screws)
- ISO 898/1 – 1978 Mechanical properties of fasteners; Part 1: Bolts, screws and studs (see DIN ISO 898 Part 1)
- ISO 965/1 – 1980 ISO general purpose metric screw threads – Tolerances; Part 1: Principles and basic data (see DIN 13 Part 14)
- ISO 965/2 – 1980 ISO general purpose metric screw threads – Tolerances; Part 2: Limits of sizes for general purpose bolt and nut threads – Medium quality (see DIN 13 Part 15)
- ISO 3506 – 1979 Corrosion-resistant stainless steel fasteners – Specifications (see DIN 267 Part 11)
- ISO 4759/1 – 1978 Tolerances for fasteners; Part 1: Bolts, screws and nuts with thread diameters  $\geq 1,6 < 150$  mm and product grades A, B and C

## b) in this standard

- DIN 13 Part 12 ISO metric screw threads; coarse and fine threads from 1 to 300 mm diameter; selection of diameters and pitches
- DIN 13 Part 15 ISO metric screw threads; fundamental deviations and tolerances for screw threads from 1 mm diameter

DIN 78	Thread ends, lengths of projection of thread ends for ISO metric screw threads as defined in DIN 13
DIN 267 Part 1	Fasteners; technical delivery conditions; general requirements
DIN 267 Part 2	(at present at the stage of draft) Fasteners; technical delivery conditions, types of finishes and dimensional accuracy
DIN 267 Part 5	Fasteners; technical delivery conditions, acceptance testing
DIN 267 Part 9	Fasteners; technical delivery conditions, components with electroplated coatings
DIN 267 Part 11	Fasteners; technical delivery conditions with supplements to ISO 3506, components made of stainless steel and acid-resistant steels
DIN 267 Part 18	Fasteners; technical delivery conditions, components made of non-ferrous metals
DIN 267 Part 19	Fasteners; technical delivery conditions, surface defects on bolts and screws
DIN 962	Screws, bolts, studs and nuts; designations, types and finishes
DIN 4000 Part 2	Tabular layouts of article characteristics for bolts, studs and nuts
DIN 6900	Screw assemblies
DIN 7500	Thread-forming screws for ISO metric screw threads
DIN ISO 898 Part 1	Mechanical properties of fasteners; bolts, screws and studs
DIN ISO 4759 Part 1	Tolerances for fasteners; bolts, screws and nuts with thread diameters $\geq 1,6$ and $\leq 150$ mm and product grades A, B and C

### Previous editions

DIN 912 Part 1 : 11.70; DIN 912 Part 2: 10.69; DIN 912: 10.33, 02.37, 04.46, 07.53, 03.61, 12.67, 09.79

### Amendments

Compared with the September 1979 edition, the following amendments have been made:

- a) The content of the standard has been revised editorially.
- b) The designation in accordance with ISO 4762 has been included.
- c) The values for  $d_a$  have been changed for sizes M 12, M 14 and M 16.
- d) The masses for sizes M 56 to M 100  $\times$  6 have been corrected.
- e) The M 18  $\times$  2, M 20  $\times$  2 and M 22  $\times$  2 fine threads have been included.
- f) The reference to the permissible product grade F for sizes up to M 2,5 has been deleted.
- g) For general requirements, reference has been made to DIN 267 Part 1 and for permissible surface defects to DIN 267 Part 19.
- h) The position of the dashed stepped line for M 12, M 16, M 18, M 20, M 30, M 36, M 42, M 48 and M 56 has been changed.

### Explanatory notes

As can be seen from the amendment section, no major or misleading amendments have been made to this revised edition of DIN 912 compared with the previous September 1979 edition. A few important points which have resulted from adopting ISO 4762 in modified form are explained below to help understand the standard:

- a) It was not possible to adopt ISO 4762 – 1977 as national Standard DIN ISO 4762 and as a replacement for the November 1970 edition of DIN 912 Part 1 and the October 1969 edition of Part 2 in unmodified form, as ISO 4762 only covers parts of the scope of these standards (M 1,6 to M 36) and does not specify any intermediate sizes. Also, ISO 4762 does not contain some international reference standards which, until they appear, have to be replaced by national standards, e. g. DIN 267 Part 5 for the acceptance test.
- b) In order to include ISO 4762 in modified form in DIN 912, the so-called shading solution, which in the meantime has also been used for other standards on fasteners, has been adopted, i. e. all the national specifications deviating from or extending beyond ISO 4762 – 1977 have been indicated by shading. Nothing has been deleted from ISO 4762.
- c) Translator's note. Paragraph c) is only of relevance to the German original and has thus been omitted from this translation.
- d) In the 1979 edition of DIN 912, some of the previous thread lengths were increased to comply with ISO 4762. After this edition was published, difficulties of conversion resulted in some cases which have, however, been resolved in the meantime. As is well known,  $b = 2d + 12$  mm applies uniformly for calculating the thread lengths.

- e) Detailed dimensions have been given for the head bearing surface and maximum underhead fillet. As before, doubts still exist about the value specified in ISO 4762 – 1977 for the bearing surface diameter  $d_w$  min. Values corresponding to  $d_w$  min. =  $d_k$  min. – IT 15 are more suitable in practice from the cold forming point of view. Discussions are being held on an international basis about a corresponding revision of ISO 4762 and ISO 4759/1 (see DIN ISO 4759 Part 1). When calculating the surface pressures, it is recommended using the following proposed values in the range M 3 to M 24:

Thread size $d$		M 3	M 4	M 5	M 6	M 8	M 10	M 12
$d_w$	ISO 4762 (DIN 912)	5,07	6,53	8,03	9,38	12,33	15,33	17,23
min.	(Proposal)	4,84	6,20	7,70	9,20	12,03	15,03	17,03

Thread size $d$		M 14	M 16	M 18	M 20	M 22	M 24
$d_w$	ISO 4762 (DIN 912)	20,17	23,17	25,87	28,87	31,81	34,81
min.	(Proposal)	19,83	22,83	25,83	28,83	31,61	34,61

- f) The previous depths of the hexagon sockets have been reduced in line with ISO 4762 for reasons of head strength and a resulting minimum base thickness  $w$  given. The tolerances for the widths across flats have been narrowed somewhat. A second type for the hexagon socket (prebored and finished) has been included.
- g) The limiting values of the individual dimensions have been included. They have been calculated in accordance with DIN ISO 4759 Part 1 (supersedes parts of DIN 267 Part 2).
- h) Instead of the previous "design m", product grade A has been given in line with DIN ISO 4759 Part 1 without any major changes to the tolerances resulting.
- j) The masses of hexagon socket head cap screws not included in ISO 4762 – 1977 have been listed in a separate table. As before, because of the tolerances on dimensions, these are approximate values.
- k) As a supplement to ISO 4762 – 1977, fine threads have been included in line with the selection described in DIN 13 Part 13. It also applies to sizes M 10 × 1 and M 12 × 1,5 not included in the international selection of thread sizes for screws (ISO 262), but which are required nationally. Efforts are being made to have ISO 262 revised.
- l) The October 1969 edition of DIN 912 Part 2 also specified product grade F in accordance with DIN 267 Part 6 for sizes up to M 2,5. However, this product grade is not usual for hexagon socket head cap screws, even in the small sizes. Therefore, it has been deleted.
- m) The technical delivery conditions have been supplemented with references to the corresponding basic standards.
- n) The contents of the standard have been aligned editorially with ISO 4762 – 1977. ISO 4762 – 1977 contains some printing errors. These have been corrected in this standard. Corresponding corrections are planned for the ISO Standard.

### International Patent Classification

F 16 B 23/00